

REV	DESCRIPTION	DATE	DRAWN	CHECK
A	ORIGINAL ISSUE	20/5/11	PK	***

ITEM	QTY	PART NUMBER	DESCRIPTION	MASS/PART	TOTAL MASS
1	12		LADDER RUNG NON SLIP	0.7	8.4
2.LH	1 SET		LADDER STRINGER BOTTOM_LH	3.7	3.7
2.RH			LADDER STRINGER BOTTOM_RH	3.7	3.7
3.LH	1 SET		LADDER STRINGER INTERM_LH	2.4	2.4
3.RH			LADDER STRINGER INTERM_RH	2.4	2.4
4.LH	1 SET		LADDER STRINGER TOP_LH	4.5	4.5
4.RH			LADDER STRINGER TOP_RH	4.5	4.5
5.LH	1 SET		PLATFORM SUPPORT BRACKET_LH	0.7	0.7
5.RH			PLATFORM SUPPORT BRACKET_RH	0.7	0.7
6.LH	1 SET		LADDER HANDRAIL_LH	3	3
6.RH			LADDER HANDRAIL_RH	3	3
7	4		STRINGER JOINT PLATE	0.3	1.2
8	2		LADDER_ANGLE FOOT	0.2	0.4
9	1		LADDER PLATFORM NON SLIP	5.4	5.4
10	1		LADDER TUBE	1.2	1.2
12	2		LADDER SAFETY HOOPER_BOTTOM	5	10
13	1		LADDER SAFETY HOOPER_TOP	5	5
14	7		SAFETY HOOPER TIE BAR	1.7	11.9
15	6		WATER TANK LADDER LEG	0.5	3
				75.1	Kgs

FASTENERS				
PART NUMBER	DESCRIPTION	QTY	Kgs/part	Total/Kgs
10860000	M10 X 25 LG H.S.S	90	0.026	2.34
10870000	M10 X 30 LG H.S.S	4	0.028	0.112
	M10 X 50 LG H.S.S	10	0.04	0.4
	M10 X 80 LG H.S.S	4	0.07	0.28
10930000	M10 NUTS	108	0.011	1.188
10950000	M10 FLAT WASHERS	108	0.0034	0.3672
14990310	M12 X 100 LG H.S.S	2	0.016	0.032
				4.7192

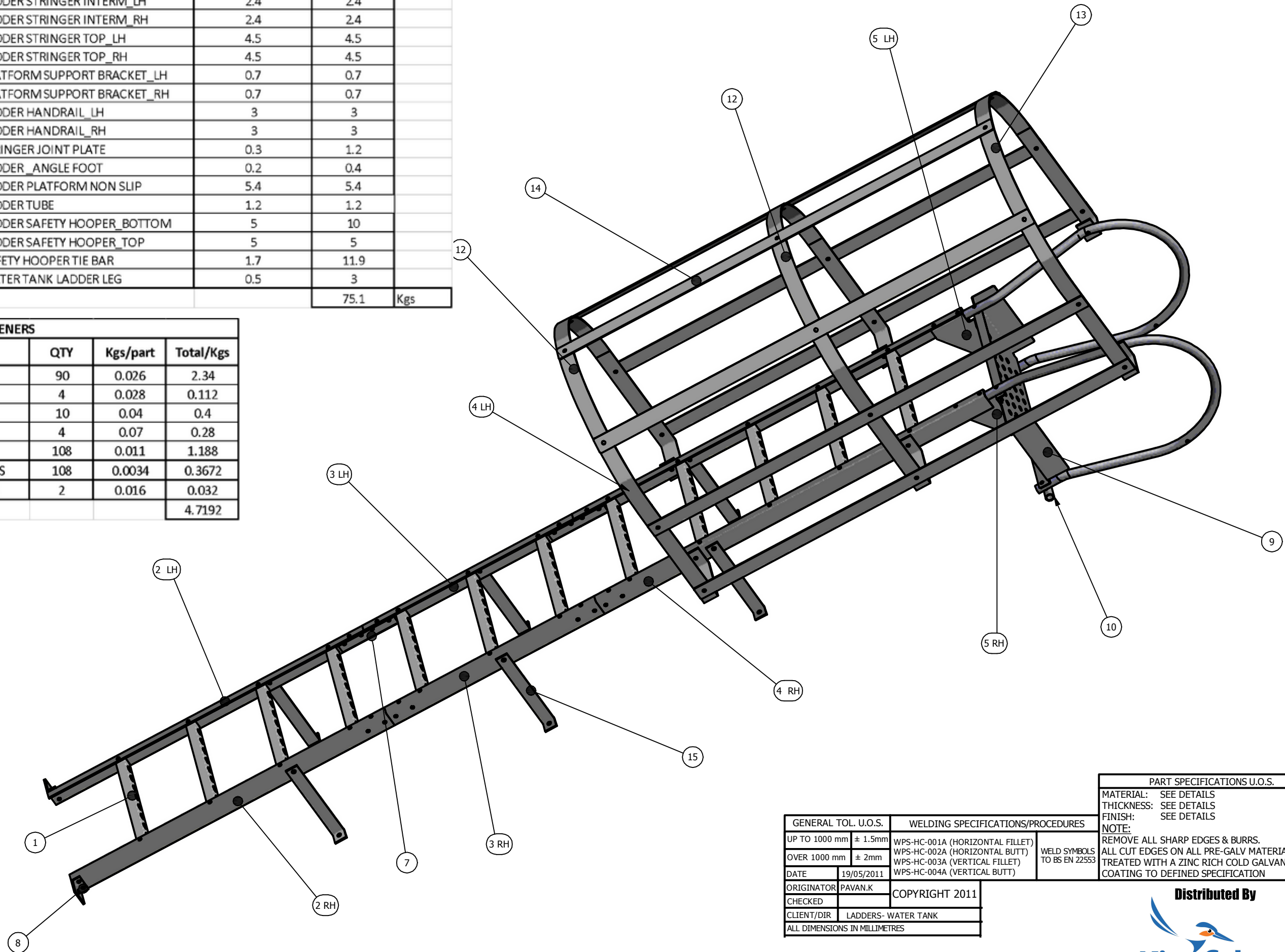

GENERAL TOL. U.O.S.		WELDING SPECIFICATIONS/PROCEDURES	
UP TO 1000 mm	± 1.5mm	WPS-HC-001A (HORIZONTAL FILLET)	WELD SYMBOLS TO BS EN 22553
OVER 1000 mm	± 2mm	WPS-HC-002A (HORIZONTAL BUTT)	
		WPS-HC-003A (VERTICAL FILLET)	
DATE	19/05/2011	WPS-HC-004A (VERTICAL BUTT)	
ORIGINATOR	PAVAN.K	COPYRIGHT 2011	
CHECKED			
CLIENT/DIR	LADDERS- WATER TANK		
ALL DIMENSIONS IN MILLIMETRES			

**PART SPECIFICATIONS U.O.S.**  
MATERIAL: SEE DETAILS  
THICKNESS: SEE DETAILS  
FINISH: SEE DETAILS  
**NOTE:**  
REMOVE ALL SHARP EDGES & BURRS.  
ALL CUT EDGES ON ALL PRE- GALV MATERIAL TO BE TREATED WITH A ZINC RICH COLD GALVANISING COATING TO DEFINED SPECIFICATION

